

8010 BILOBA®

 8±13,52 mm	 1000mm	 100kg	 -15 °C  +40 °C
--	--	---	--

- Cerniera oleodinamica con regolazione delle velocità di chiusura dell'anta. Stop a 0° +90° -90°. Adatta anche per porte in battuta.
- Bisagra cierra puerta hidráulica con ajuste de velocidad de cierre de la puerta. Freno a 0°, + 90°, -90°. Adecuada por puertas con tope.
- Hydraulic hinge with adjustment of the closing speed of the door. Stop at 0° +90° -90°. Suitable for doors with stop.
- Automatik-, Hydraulikscharnier mit Regulierung der Schließgeschwindigkeit der Tür. Feststellung bei 0° +90° -90°. Für Anschlagtüren geeignet.

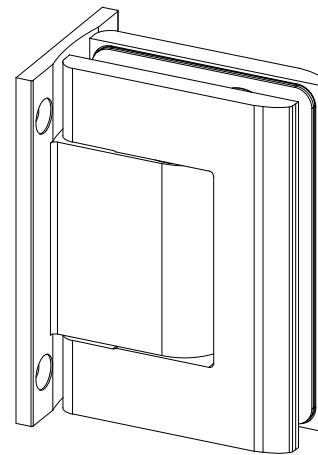

DISPONIBILE ANCHE NELLE VERSIONI: 1) SENZA FERMI A 90° PER GLI ART. 8010, 8011 E 8015 - 2) "L" LIGHT CON MOLLA DEPOTENZIATA PER PORTE DI LARGHEZZA INFERIORE A 700 MM PER L'ART. 8060. Versioni da specificare in fase d'ordine e soggette a possibili minimi d'ordine. Per ulteriori informazioni contattare l'ufficio commerciale.

TANBIEN DISPONIBLE: 1) SIN RETENCIÓN A 90° POR LOS ARTÍCULOS 8010, 8011 Y 8015 - 2) "L" LIGHT - MUELLE CON MENOS FUERZA PARA PUERTAS INFERIORES A 700MM DE ANCHO POR EL ART 8060. Se tendrá que especificar en los pedidos y ser objeto de pedido mínimo. Nuestra oficina comercial está a su disposición para ampliar esta o cualquier otra información.

AVAILABLE IN FURTHER TWO VERSIONS: 1) WITHOUT 90° STOP FOR ITEMS 8010, 8011 AND 8015 - 2) "L" LIGHT WITH WEAKENED SPRING FOR DOORS WITH WIDTH LESS THAN 700MM FOR ITEM 8060. Both have to be specified on being ordered and could be subjected to minimum quantity order. For further information, please get in touch with the export department.

ES IST AUCH IN ANDEREN 2 VERSIONEN VERFÜGBAR: 1) OHNE 90° ARRETIERUNG FÜR ARTIKELNUMMER 8010, 8011 UND 8015 - 2) "L" LIGHT MIT SCHWÄCHERER FEDER FÜR TÜREN UNTER 700 MM BREITE FÜR ARTIKELNUMMER 8060. Beide sind bei der bestellung anzugeben und könnten eine mindestbestellmenge verlangen. Für weitere informationen setzen sie sich mit unserer exportabteilung im kontakt.

Classificazione secondo normativa - Clasificación según la ley - Classification according to the law Klassifizierung nach den Vorschriften						
art. 8010	UNI EN 1154:2006	3	8	$\frac{2}{5}$	0	1 4

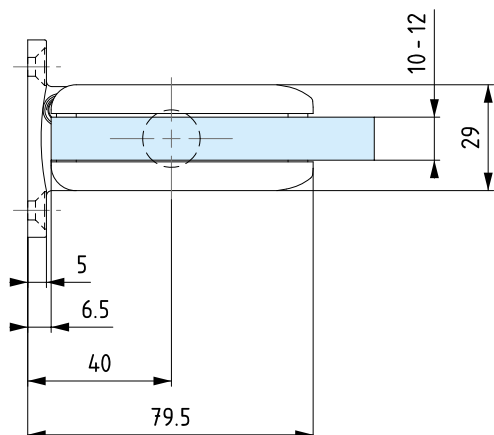
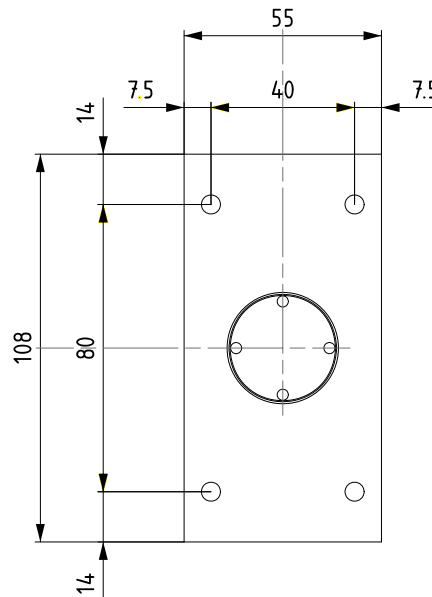
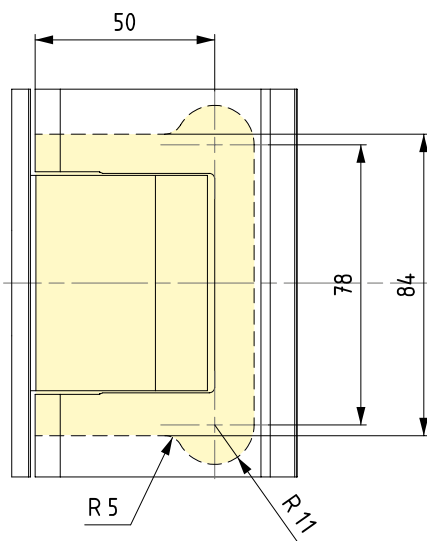

Valvola di regolazione velocità chiusura anta
 Ajuste de velocidad de cierre de la puerta
 Adjustment valve for closing speed of glazed
 Regelsventil für die Türschließgeschwindigkeit

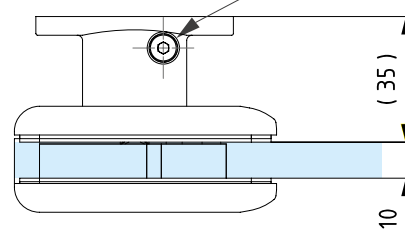

TESTATA 1.000.000 CICLI.
 PROBADA EN 1.000.000 ABERTURAS.
 TESTED FOR 1.000.000 CYCLES.
 GETESTET FÜR 1.000.000 ÖFFNUNGEN.