

CUSTOMIZE YOUR FINISH

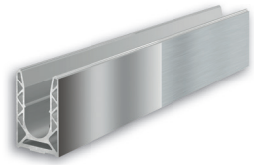

ANODIZED ALUMINUM

Anodizing is an electrolyte process used to increase the thickness of the natural oxide layer.

The process provides better corrosion and wear resistance to aluminum products.



BRUSHED STEEL EFFECT ALUMINUM

Brushed or dull polished metal with a unidirectional satin finish.

It is produced by polishing the metal with a 120-180 grit belt or wheel then finishing with an 80-120 grit greaseless compound or medium non-woven-abrasive belt or pad.

Finishing possible on profiles and claddings



RAL

RAL is a European color matching system. It defines colors for paint, coatings and plastics.

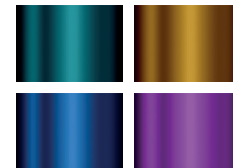

RAL Effect includes 420 solid colors and in particular 70 metallic colors.

Finishing possible on profiles and claddings



WOOD SPECIAL

Made by SADEV

Finishing possible on claddings

LIGHT UP YOUR BALUSTRADE

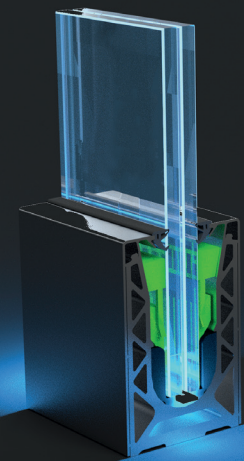

Enhance your project and its appearance by **adding lighting.**

We propose the full kit accessories with waterproof LED lighting in different colours to light up your balustrade.



SADEV USA - SABCO Flyer - 17x11-GB - 09/2020



We Build the Invisible

SABCO[®]
SADEV BALUSTRADE CONCEPT



We Build the Invisible

Tel.: 319-524-5600 | info@sadevusa.com

sadevusa.com

follow us on



MOUNTING TYPE

INSTALL TO FIT

1 CLADDING WITH SEAL

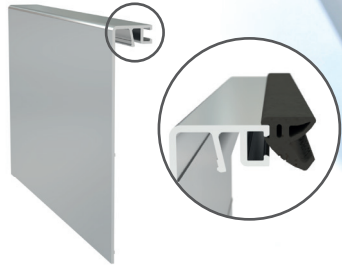

2 GLASS ADJUSTMENT

SABCO's wedge system aligns the glass for a quicker and easier installation.

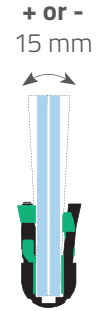

3 ONE SIDE ONE STEP!

Easy adjustment thanks to the clamps, no other installation requirements except tightening!

WHICH SYSTEM IS FOR YOUR PROJECT?

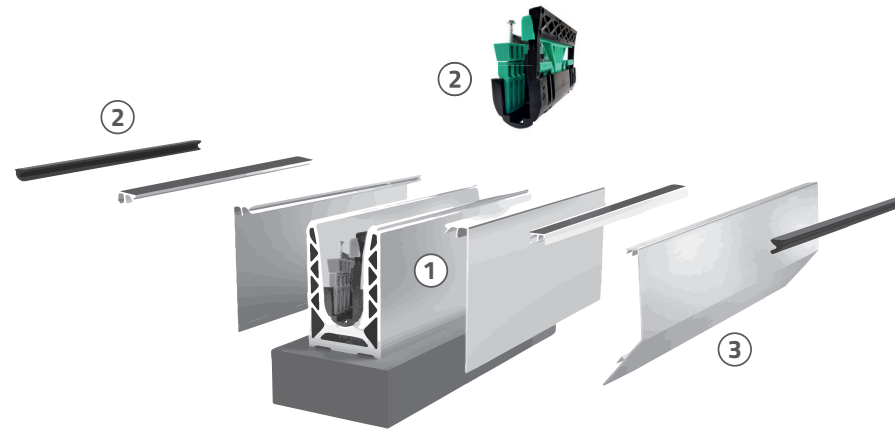

1

CHOOSE YOUR BALUSTRADE

For the installation of your glass balustrade, SADEV® is able to offer you a large choice of systems.

To choose the right profile according to your project, it is necessary to take into account these 3 criteria:

- A the type of application
- B the fixing surface
- C the type of installation

2

COMPLETE IT!

Once the profile has been selected, you must complete the assembly of your guardrail with the corresponding shims and joints.

Choose the shims according to the thickness of the glass.

The choice of joints will be made according to the shims used.

All our accessories are tested and approved.

3

FINALIZE YOUR SOLUTION

Our engineers have developed a wide range of cladding to meet your specific project requirements.

SABCO's cladding range is compatible with one side and double side wedges as well as with our complete SABCO balustrade product range.

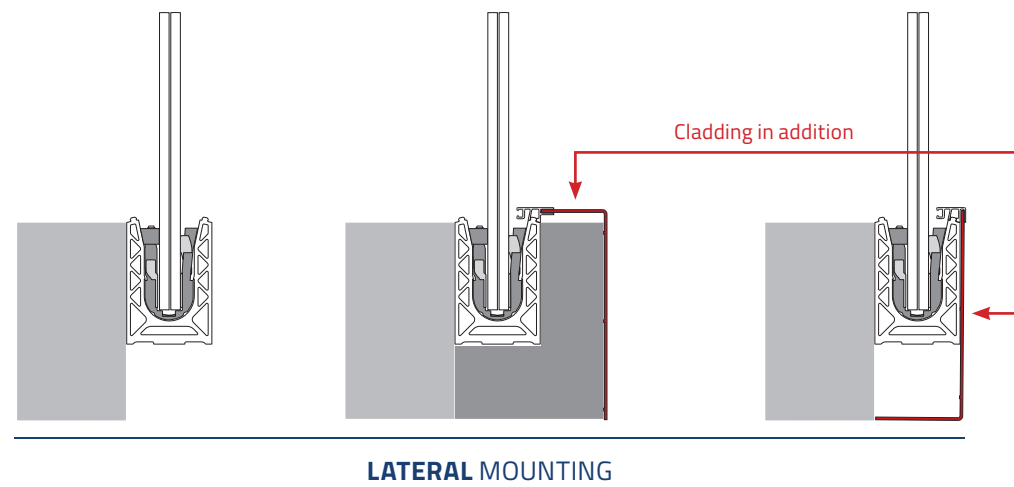
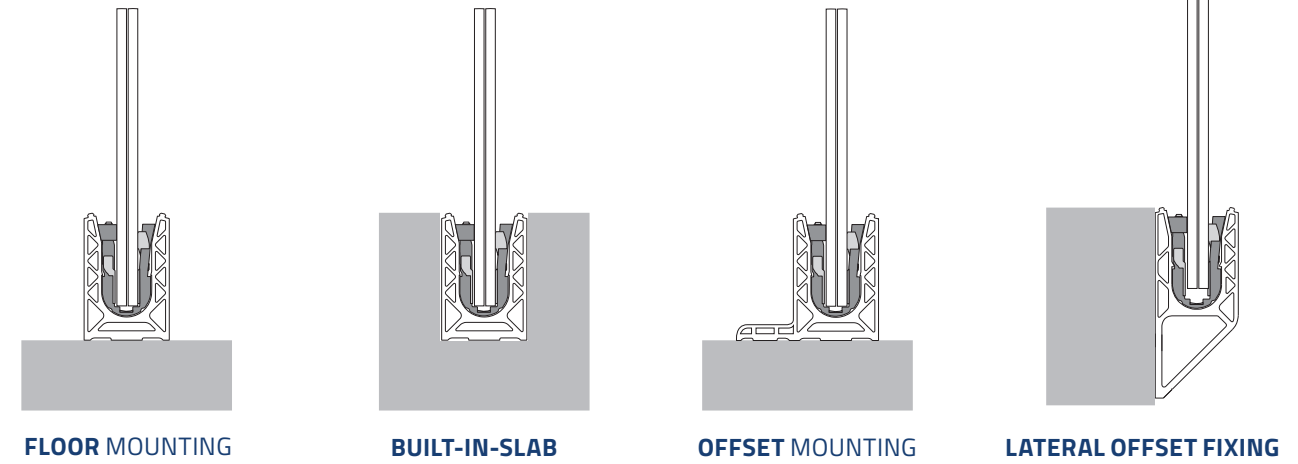

FLOOR MOUNTING PROFILE

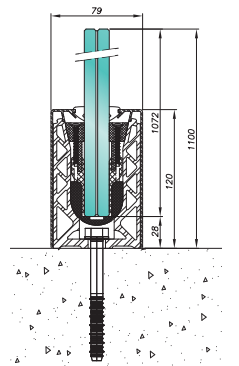

CAD files of other profiles available upon request

DIFFERENT TYPES OF APPLICATIONS

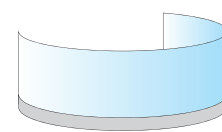

CURVED

Curved railings. Bending is possible from a minimum radius of 1 metre.

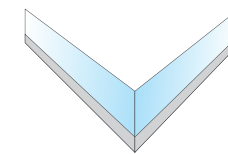

TAILOR MADE

Adapts to even the tightest corners.

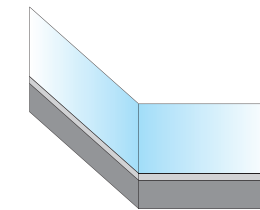

INCLINE

Up to 40° angle to the horizontal.



OVERSIZE

Suitable for high glasses, above of 1.1m

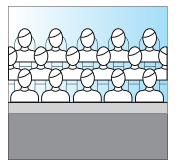

HEAVY DUTY

C5 / UEFA stadium and high performance application