

# R 1001

Designation : swivel fitting, countersunk head



REFERENCE TO ORDER			
GLASS THICKNESS	Ø AXIS	LENGTH AXIS (mm)	ARTICLE CODE
$8 \leq V \leq 15$	M14	65	R1001-0815-1465*
$15 < V \leq 22$	M14	65	R1001-1522-1465
$22 < V \leq 26$	M14	65	R1001-2226-1465
SPECIAL	SPECIAL	SPECIAL	R1001-V-SP

Patent No : 9806556  
 Technical assessment available online : [www.sadev.com](http://www.sadev.com)  
 Sealing strip between glazing available p.8.26

\* R1001-0815-1465 : model - Glass Thickness - type axis and length.  
 Seismic swivel fitting optional.

## Dimensions

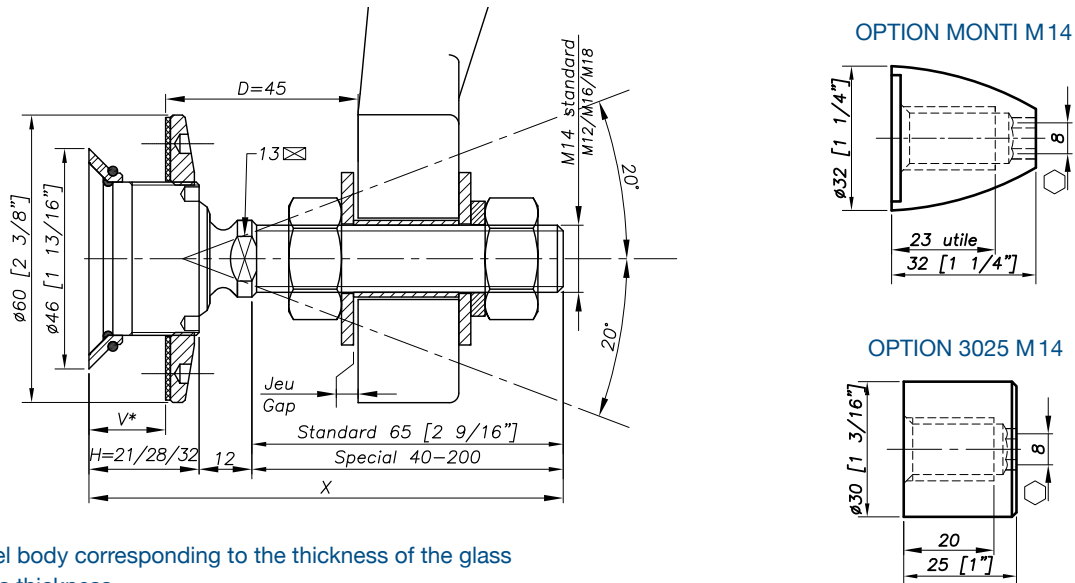

H = Swivel body corresponding to the thickness of the glass  
 V \* = glass thickness

## Glass drilling

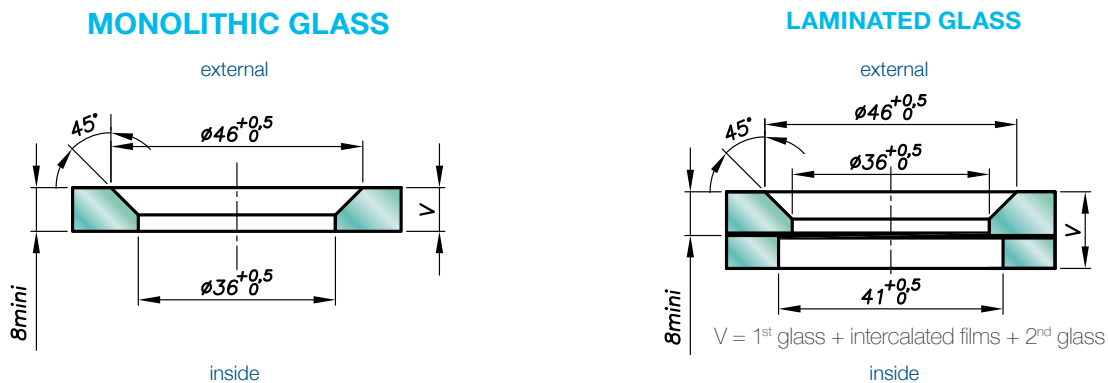

Available for glass thicknesses from 8 to 31.52 mm, for other thicknesses please consult us.

It is important to provide the following information with each request: the glass composition (ex.: 10 mm monolithic, 8.8.4 laminated, 8.8.2-12-10 insulating) / the length and diameter of the threaded axle if not standard dimensions (M14, 65 mm) / the reference of the spider to be used as support, or the thickness of an existing support for the delivery of the spacer.

## Mechanical performance

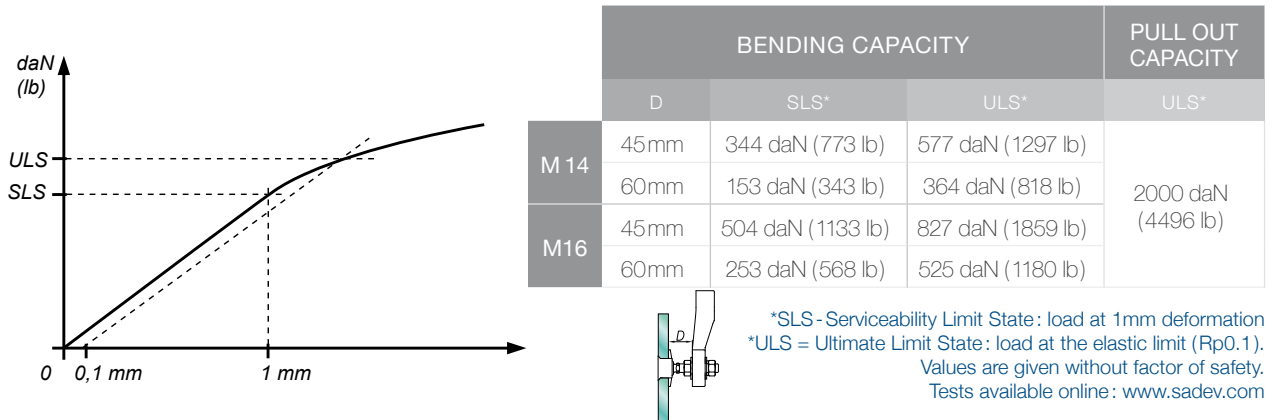

## Components

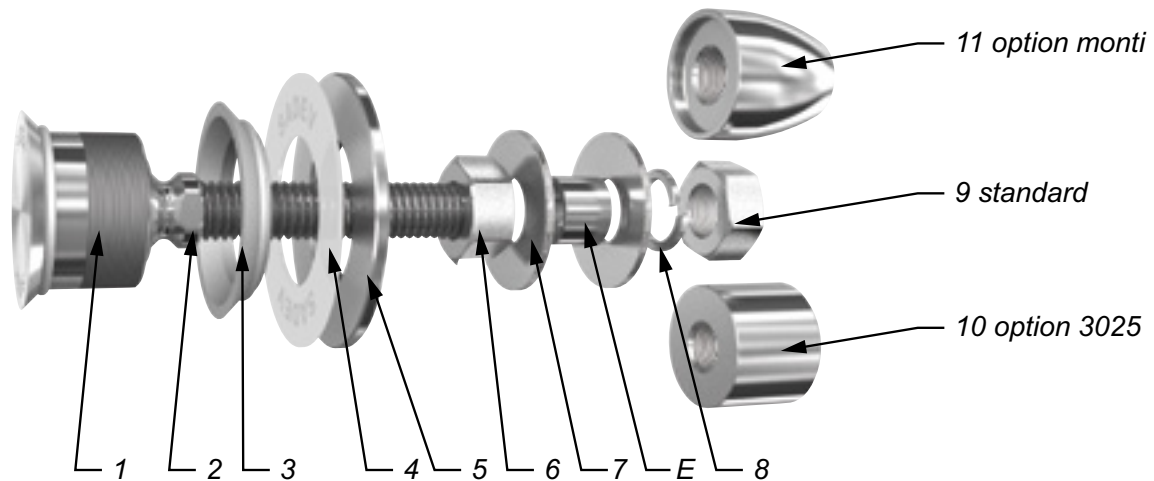

MARK	QUANTITY	DESIGNATION	MATERIAL
1	1	Swivel body	X2 Cr Ni Mo 17.12.2 as per EN 10088-3
2	1	Threaded Axle	X4 Cr Ni Mo 16.5.1 as per EN 10088-3
3	1	Glass Hole Grommet	AW-1050A as per EN 573-3 / Al 99.5%
4	1	Contact washer	White polyacetyl / white polyethylene
5	1	Glass Nut Ø60	X2 Cr Ni Mo 17.12.2 as per EN 10088-3
6	1	Nut DIN 934	A4
7	2	Washer	A4
8	1	Lock Lock washer DIN127	A4
9	1	Nut DIN 934	A4
10	1	3025 Cap Nut - Option	X2 Cr Ni Mo 17.12.2 as per EN 10088-3
11	1	Monti Cap Nut - Option	X2 Cr Ni Mo 17.12.2 as per EN 10088-3

## Suggested mounting instruction

Insert parts N° 1/2 and 3 into the glass.

Mount contact washer N° 4 and nut N° 5 and tighten to 20Nm (15 ft-lb) for monolithic glass and 10Nm (7.5 ft-lb) for laminated glass using SADEV tools Mark. 097581160 and Mark. CLE-DYN-072031. Mount nut N° 6 and washer N° 7.

Insert the threaded axle into the support with spacer E (available on request), see technical page. Adjust the depth. Mount washer N° 7, lock washer N° 8, and nut N° 9. Tighten to 60Nm (45 ft-lb) using a 22 mm wrench.

SADEV recommends using thread locking compound whenever possible.