

R 1001 A

Designation : swivel fitting, countersunk head - insulated glass unit



REFERENCE TO ORDER			
GLASS THICKNESS	Ø AXIS	LENGTH AXIS (mm)	ARTICLE CODE
Bespoke glass thickness	M14	65	R1001A-V-1465*
SPECIAL	SPECIAL	SPECIAL	R1001A-V-SP

* R1001A-V-1465 : Model - Glass thickness - Type axis and length.

Patent No : 9806556

Technical assessment available online : www.sadev.com

Sealing strip between glazing available p.8.26

Dimensions

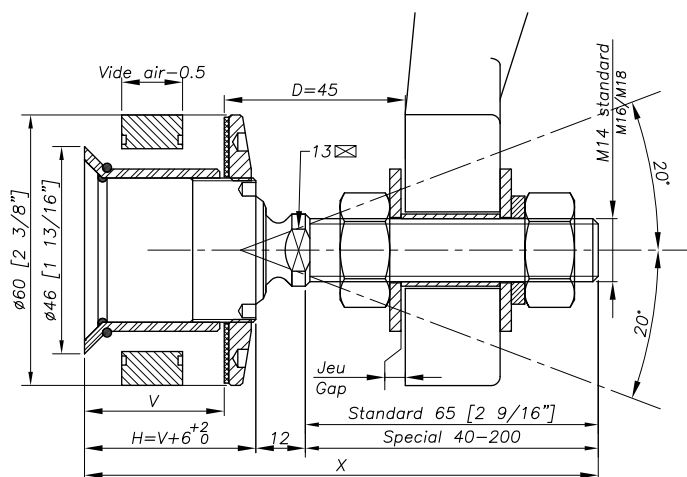

OPTION MONTI M 14

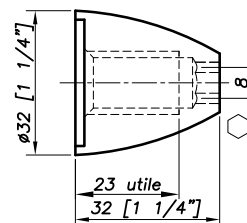

OPTION 3025 M 14

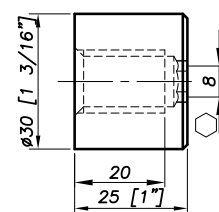

H = Swivel body corresponding to the thickness of the glass.

V* = glass thickness

Glass drilling

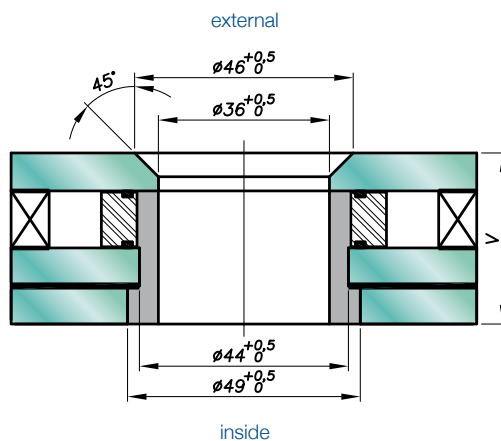

It is important to provide the following information with each request: the glass composition (ex.: 10 mm monolithic, 8.8.4 laminated, 8.8.2-12-10 insulating) / the length and diameter of the threaded axle if not standard dimensions (M14, 65 mm) / the reference of the spider to be used as support, or the thickness of an existing support for the delivery of the spacer.

Mechanical performance

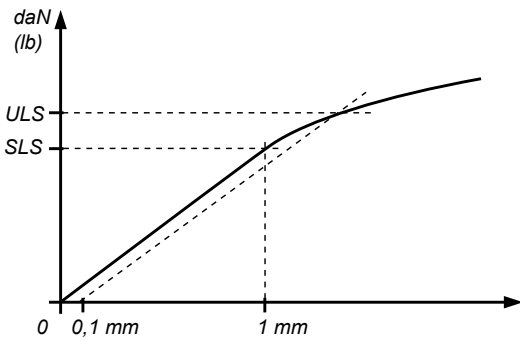

	BENDING CAPACITY			PULL OUT CAPACITY
	D	SLS*	ULS*	ULS*
M 14	45mm	344 daN (773 lb)	577 daN (1297 lb)	2000 daN (4496 lb)
	60mm	153 daN (343 lb)	364 daN (818 lb)	
M16	45mm	504 daN (1133 lb)	827 daN (1859 lb)	
	60mm	253 daN (568 lb)	525 daN (1180 lb)	

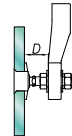

*SLS - Serviceability Limit State: load at 1mm deformation
 *ULS = Ultimate Limit State: load at the elastic limit (Rp0.1).
 Values are given without factor of safety.
 Tests available online: www.sadev.com

Components

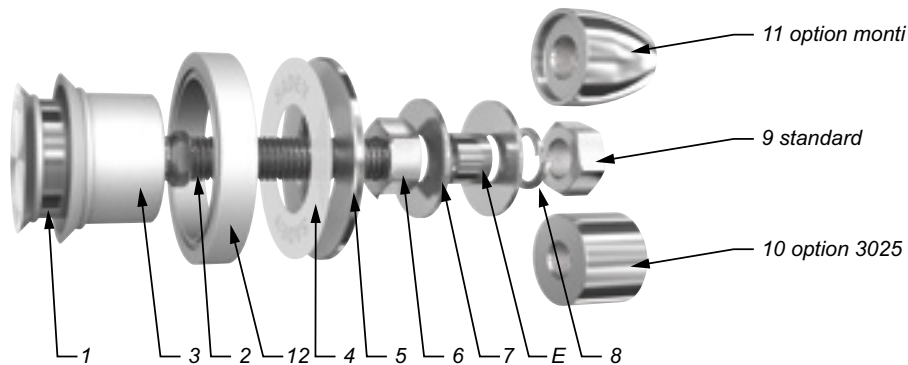

MARK	QUANTITY	DESIGNATION	MATERIAL
1	1	Swivel body	X2 Cr Ni Mo 17.12.2 as per EN 10088-3
2	1	Threaded Axle	X4 Cr Ni Mo 16.5.1 as per EN 10088-3
3	1	Glass hole grommet	AW-1050A as per EN 573-3/Al 99.5%
4	1	Contact washer	White polyacetyl/white polyethylene
5	1	Glass nut Ø60	X2 Cr Ni Mo 17.12.2 as per EN 10088-3
6	1	Nut DIN 934	A4
7	2	Washer	A4
8	1	Lock washer DIN127	A4
9	1	Nut DIN 934	A4
10	1	3025 Cap nut - Option	X2 Cr Ni Mo 17.12.2 as per EN 10088-3
11	1	Monti cap nut - Option	X2 Cr Ni Mo 17.12.2 as per EN 10088-3
12	1	Spacing ring	AlCu4MgSi/2017A (AU4G) as per EN 573-3

Suggested mounting instruction

1 – In factory : assembly of glass

Suggested method only, not considered to replace the recommendations of the glass manufacturer. Mount spacing ring N° 12 between the two pieces of glass using 3 mm butyl cord applied into the grooves. Assemble the IG unit. Insert glass hole grommet N°3 and secure using a neutral cure silicone.

2 – On site

Insert parts N° 1/2 into the glass hole. Place the contact washer N° 4 over assembly N° 1/2 and thread on the glass nut N° 5. Tighten to 10Nm (7.5 ft-lb) for tempered glass using SADEV catalog ref. 097581160 and ref. CLE-DYN-072031. Thread on nut N° 6 and apply washer N° 7. Insert the threaded axle into the support with spacer E (available on request), see technical page. Adjust the depth. Mount the second washer N° 7, lock washer N° 8, and nut N° 9. Tighten to 60Nm (45 ft-lb) using a 22 mm wrench.

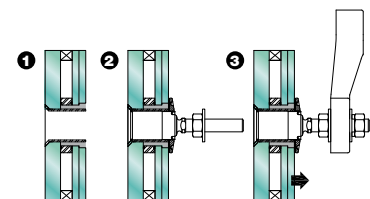

SADEV recommends using thread locking compound whenever possible.