

V 2001

Designation : fixed bolt, countersunk head



REFERENCE TO ORDER			
GLASS THICKNESS	Ø AXIS	LENGTH AXIS (MM)	ARTICLE CODE
$8 \leq V \leq 15$	M14	65	V2001-0815-1465*
$15 < V \leq 22$	M14	65	V2001-1522-1465
$22 < V \leq 26$	M14	65	V2001-2226-1465
Special	Special	Special	V2001-V-SP

Sealing strip between glazing available p.8.26

* V2001-0815-1465 : Model - Glass Thickness - type axis and length

Dimensions

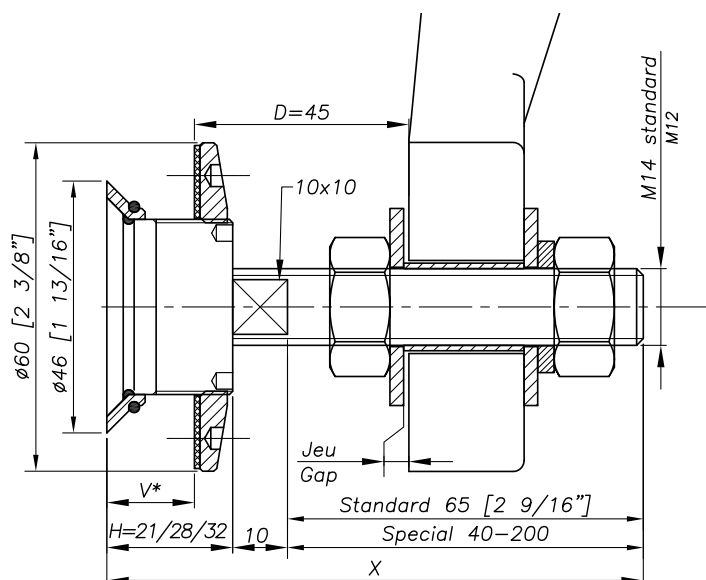

MONTI CAP NUT - OPTION M14

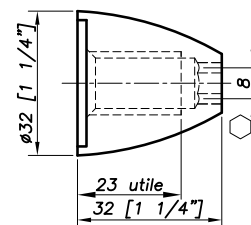

3025 CAP NUT - OPTION M14

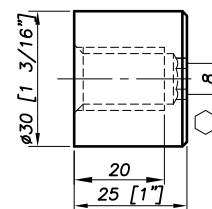

H= Swivel body corresponding to the thickness of the glass.

V* = glass thickness.

Glass drilling

MONOLITHIC GLASS

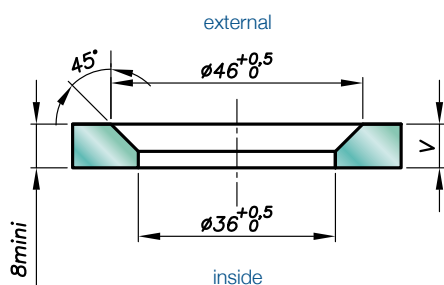

LAMINATED GLASS

V = 1st glass + intercalated films + 2nd glass

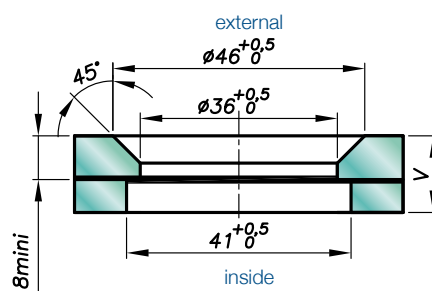

Available for glass thicknesses from 8 to 31.52 mm, for other thicknesses please consult us.

It is important to provide the following information with each request : the glass composition (ex.: 10mm monolithic, 8.8.4 laminated, 8.8.2-12-10 insulating) / the length and diameter of the threaded axle if not standard dimensions (M14, 65mm) / the reference of the spider to be used as support, or the thickness of an existing support for the delivery of the spacer.

Mechanical performances

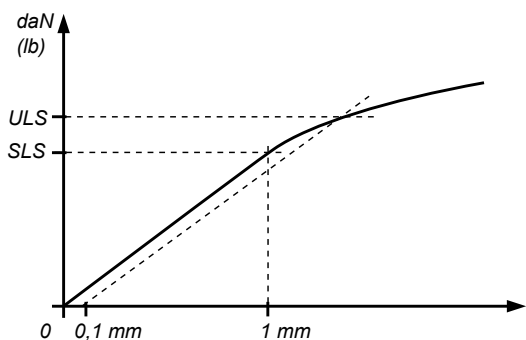

	BENDING CAPACITY			PULL OUT CAPACITY
	D	SLS*	ULS*	ULS*
M12	45 mm	127 daN (285 lb)	269 daN (604 lb)	
	60 mm	65 daN (146 lb)	147 daN (330 lb)	
M14	45 mm	317 daN (712 lb)	538 daN (1209 lb)	4959 daN (11 148 lb)
	60 mm	144 daN (323 lb)	313 daN (703 lb)	



*SLS : Serviceability Limit State : load at 1 mm deformation
 *ULS : Ultimate Limit State : load at the elastic limit (Rp0.1)
 Values are given without factor of safety
 Tests available online : www.sadev.com

Components

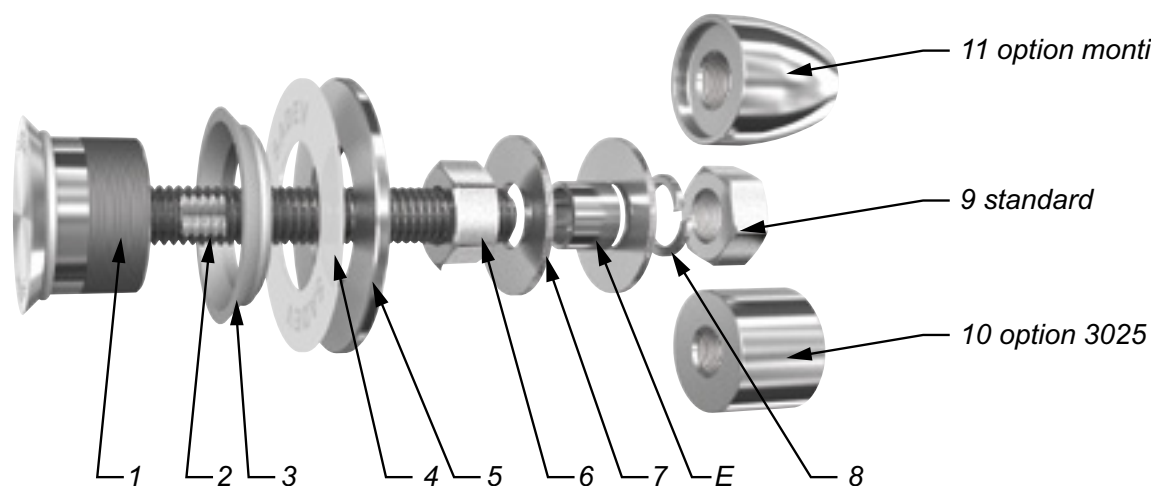

MARK	QUANTITY	DESIGNATION	MATERIAL
1	1	Body	X2 Cr Ni Mo 17.12.2 as per EN 10088-3
2	1	Threaded axle	A4
3	1	Glass hole grommet	AW-1050A as per EN 573-3 / AI 99.5%
4	1	Contact washer	White polyacetyl / white polyethylene
5	1	Glass nut Ø 60	X2 Cr Ni Mo 17.12.2 as per EN 10088-3
6	1	Nut DIN 934	A4
7	2	Washer	A4
8	1	Lock washer 127	A4
9	1	Nut DIN 934	A4
10	1	3025 Cap Nut - Option	X2 Cr Ni Mo 17.12.2 as per EN 10088-3
11	1	Monti Cap Nut - Option	X2 Cr Ni Mo 17.12.2 as per EN 10088-3

Suggested mounting instruction

Insert parts No.1/2 and 3 into the glass.

Mount contact washer No.4 and glass nut No.5 and tighten to 20Nm (15 ft-lb) for monolithic glass and 10Nm (7.5 ft-lb) for laminated glass using SADEV tools ref. 0975860 and ref. CLE-DYN-072031.

Mount nut No.6 and washer No.7.

Insert the thread axle into the support with spacer E (available on request), see technical page. Adjust the depth.

Mount washer No.7, lock washer No.8, and nut No.9. Tighten to 60Nm (45 ft-lb) using a 22mm wrench.

SADEV recommends using thread locking compound whenever possible.