



We Build the Invisible

# RECOMMENDATIONS FOR MAINTENANCE

ALUMINUM OF SADEV'S PRODUCTS

To maintain the aesthetic and mechanical qualities of aluminum, **Sadev** recommends regular maintenance operations.

**The following recommendations are not exhaustive but summarize the sensitive points to consider.**



# 1 PRECAUTIONS DURING MANUFACTURING

From the conception of your project to delivery, all our attention is focused on the parts during manufacturing, packaging, storage, and preparation for shipment. Our teams work daily for your satisfaction.

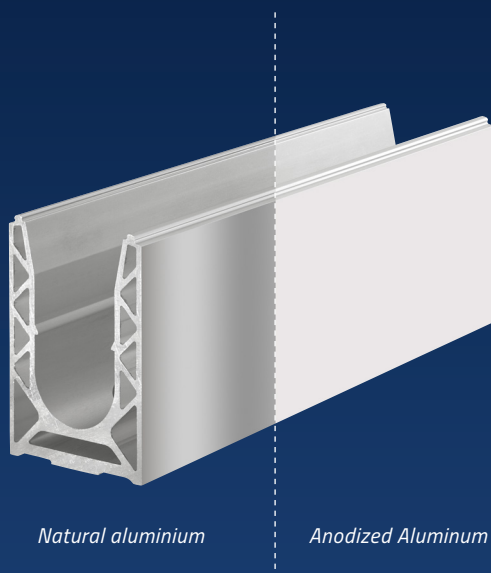

## ANODIZING: PRINCIPLE OF ALUMINUM PROTECTION

Aluminum naturally generates an oxide layer that protects it from corrosion.

Unlike most metals, it can be used even in the following applications if it's oxidized on the surface. Moreover, without this oxide layer, it would be unsuitable for most applications.

Different types of surface treatments can further improve this resistance (anodizing, lacquering, ...).

**All our aluminum products have a protective anodising layer of at least 20 µm** (a common protection in the building industry) **applied after the machining process** (drilling and cutting with anodic protection).

# 2 PRECAUTIONS BEFORE INSTALLATION

In order to preserve the characteristics of aluminum, it is essential to store and handle it with care and work in the cleanest possible environment until the project is delivered.

It is therefore necessary to take care of the site environment and to respect certain work rules, in order to avoid, among other things:

- **Ferrous pollution:** steel particles are deposited on the aluminum when the same tools are used to work steel and then aluminum, or when steel is worked close to aluminum (welding, grinding). We recommend using different tools, especially for cutting (saw blades for example).
- **Galvanic corrosion:** alteration when a metal or alloy is electrically coupled to a metal or different alloy (e.g. Alu+ Stainless Steel / Alu + Steel).

Insulate the 2 metals with a neutral material (POM, Polyethylene, etc.) in order to limit contact.

- **Chemical pollution:** caused by the discharge of chemical products of both industrial and domestic origin. They can result in particular from the use of pesticides, detergents or even from heavy metals.

### ▪ **WARNING:**

- **Aggravating factor:** the combination of the following factors: saline environment, temperature, chlorinated environment, generate an acceleration of the corrosion process. This acceleration varies according to the combination of these different factors. Precautions must be taken into consideration.
- **Other pollution or corrosions are possible depending on site conditions.**



- **WARNING:** Do not use chemicals that are incompatible with aluminum, including for cleaning (e.g. chlorinated products, acids, alkaline products, etc.).

It is impossible for us to list all the types of pollution that can alter the quality of aluminum because of multitude of factors can come into play.

## 3 SITE CLEANING

At the end of the work, it is essential to clean any residue with water and a mild detergent (PH between 5 and 8, such as dish-washing liquid, soap), rinse with clear water, then wipe off.

**Each cleaning movement must follow the length of the profile.**

As aluminum and its finishes are sensitive to acidic (pH < 5) and alkaline (pH > 8) products, it is strongly recommended not to clean with household products such as:

- **Hydrochloric acid, soda, vinegar and alkali.**

All cleaning must be tested beforehand on a less visible part.

### **PAY ATTENTION TO THE CLEANING PROCESS:**

All cuts must be protected.

- Soft cloth or sponge without abrasive parts. Your cleaning process must imperatively take into account the polishing direction.
- Water + soap. No abrasives. The cleaning must be done within 15 days after the start of the work. It is also important to clean at the completion of work. **ANY RE-POLLUTED AREA MUST BE RE-CLEANED.**

## 4 ROUTINE MAINTENANCE / MAINTENANCE OF YOUR SITE

For routine maintenance, we recommend the same type of cleaning that is carried out at the completion of work, i.e. the use of soap and water, followed by rinsing with clear water and wiping.

**This must be regular and scheduled according to the type of building and its location.**

The frequency of cleaning depends on the environment and the concentration of dirt on the surface.

The more frequent the cleaning, the easier and more economical it is. This operation can be combined with the cleaning of the glazing.

In the case of light soiling or deposits (lime-scale, sea salts, etc.), slightly abrasive cleaning products of type F, specifically developed for this application, or non-aggressive fibers coated with fine, neutral polishing powder can be used.

In the case of very heavy soiling (due to lack of maintenance) requiring renovation, it is recommended to turn to a specialized company.

### REGULARLY MAINTAINED SURFACES

- Washing with water with wetting agent (pH between 5 and 8)
- Thoroughly rinse with clean water
- Wiping with a soft, absorbent cloth

### MODERATELY SOILED SURFACES

- Washing with water with a «cleaner and shine remover» added
- Thoroughly rinse with clean water
- Wiping with a soft, absorbent cloth

### HEAVILY SOILED SURFACES

- Contact a specialist company



## 5 FREQUENCY OF CLEANING (As an indication)

IN RURAL OR SPARSELY POPULATED URBAN AREAS	IN URBAN, INDUSTRIAL OR MARINE ENVIRONMENTS	THE CLEANING OF PARTS NOT NATURALLY WASHED BY RAINWATER
<ul style="list-style-type: none"> <li>Where there are no aggressive elements in the environment, the frequency of maintenance for surfaces regularly washed by rainwater is generally annual.</li> </ul>	<ul style="list-style-type: none"> <li>Require quarterly or semi-annual maintenance depending on the amount of product exposure.</li> </ul> <p>In areas close to chemical industries or by the sea, the operation should be repeated every month to avoid stains caused by salt or other corrosive materials.</p>	<ul style="list-style-type: none"> <li>(Areas with high traffic and high loads such as building entrances, shop fronts, etc.) must be carried out more frequently than for exposed surfaces.</li> </ul>

### Reference:

<https://www.aluminum.fr/aluminum/proprietes-aluminum>

<https://www.lenntech.fr/periodique/elements/al.htm>

<https://www.futura-sciences.com/sciences/definitions/chimie-aluminum-14515/>

<https://www.adal-aluminum.fr/entretien-de-laluminum-anodise/>





We Build the Invisible

# RECOMMENDATIONS FOR MAINTENANCE

STAINLESS STEEL OF SADEV'S PRODUCTS

To maintain the aesthetic and mechanical qualities of stainless steel, **Sadev** recommends regular maintenance operations.

**The following recommendations are not exhaustive but summarize the sensitive points to consider.**



# 1 PRECAUTIONS DURING MANUFACTURING

From the conception of your project to delivery, all our attention is focused on the parts during manufacturing, packaging, storage, and preparation for shipment. Our teams work daily for your satisfaction.



## STAINLESS STEEL: STAINLESS DOES NOT MEAN UNALTERABLE.

Stainless steel has a passive and invisible layer.

In the event of deterioration, 2 possibilities are possible for it to reconstitute itself:

- **Naturally or by chemical means (passivation).**

# 2 PRECAUTIONS BEFORE INSTALLATION

## ▪ **WARNING:**

- Do not work on materials other than stainless steel in the vicinity (be careful not to use tools dedicated to working with stainless steel)
- Work in a salt/chlorinated environment with care
- **Storage of SADEV materials in a dust-free, temperate and dry environment.**

In order to preserve the characteristics of stainless steel, it is essential to store it, handle it, etc. with care and work in the cleanest possible environment until the project is delivered.

It is therefore necessary to take precautions at the site environment and to use certain work rules, among other things:

- **Ferrous pollution:** steel particles are deposited on stainless steel when the same tools are used to work steel, then stainless steel; or when working with steel near stainless steel.
- **Galvanic corrosion:** it is necessary to insert an insulator where 2 metals of different nature are in contact.
- **Chemical pollution:** do not use chemical products that are incompatible with stainless steel, for cleaning (e.g. chlorinated products).

## ▪ **WARNING:**

- **Aggravating factor:** the combination of the following factors: saline environment, temperature, chlorinated environment, generate an acceleration of the corrosion process. This acceleration varies according to the combination of these different factors. Precautions must be taken into consideration.
- **Other pollution or corrosion is possible depending on site conditions.**

It is impossible for us to list all the types of pollution that can alter the quality of stainless steel because of multitude of factors can come into play.

If in doubt, we advise you to use a company specialised in cleaning.



## 3 SITE CLEANING

During your work and depending on the duration of the work, it is essential to clean the residues and dust that may have been deposited on the SADEV parts with soap and water, rinse with clear water, then wipe off.

We recommend thoroughly cleaning if the construction site lasts more than 30 days.

**Each cleaning movement must follow the length of the profile.**

When using chemical cleaning products, it is essential to comply with the safety and environmental regulations relating to the product chosen.

These products must be used in diluted quantities (follow the instructions of the cleaning product).

All cleaning must be tested beforehand on a less visible area.

**The use of chlorinated products is to be prohibited (e.g. hydrochloric acid, bleach).**

### **PAY ATTENTION TO THE CLEANING PROCESS:**

All cuts must be protected.

- Soft cloth or sponge without abrasive parts. Your cleaning process must imperatively take into account the polishing direction.
- Water + soap. No abrasives. The cleaning must be done within 15 days after the start of the work. It is also important to clean at the completion of work. **ANY RE-POLLUTED AREA MUST BE RE-CLEANED.**

## 4 ROUTINE MAINTENANCE / MAINTENANCE OF YOUR SITE

For routine maintenance, we recommend the same type of cleaning as that must be carried out at the end of work, i.e. the use of soap and water, followed by rinsing with clean water and wiping.

This must be regular and scheduled according to the type of building and its location.

- **If close to the sea or salt**, near a road (which may be salty), the cleaning needs should be planned.
- **Chlorine-laden environments** (e.g. swimming pools) require special attention.
- **Industrial buildings** could have a sulphur content in the air.
- **Visual discolouration of stainless steel** could mean that a corrosion process has started. This must be dealt with seriously and without delay.

The frequency of cleaning depends on the environment and must be scheduled according to local conditions.

**In general we strongly recommend a maintenance contract for SADEV parts.**

